

Low-cost charging systems with full communication capability.

Cyriacus Bleijs

EDF DTVE

Electric vehicles and Transportation
28 Rue Jacques Ibert, Paris, 75177 France
cyriacus.bleijs@edf.fr, +33 607 47 97 60

The EDF charging system has been specifically designed to reduce the global cost of infrastructure both in terms of the initial investment and in terms of the total cost to the supplier and the client. This work was initiated in 2005 using the on-board screen of the vehicle and a PLC transmission on the earth line to vastly increase safety while simultaneously reducing the over-all cost. The new system now includes several communications schemes that simplify the client interaction and are adapted to various billing methods. This system allows a very efficient and secure identification of the client and is complementary to the high data channels proposed elsewhere. The new system has been designed to minimize the difficulties of integration into existing vehicles while still being able to profit of all the advantages of future vehicle designs.

Keywords: infrastructure, communication, safety, standardization

1 Introduction

The charging system described in this article has been specifically designed to reduce the global cost of infrastructure thus rendering the EV more attractive to the client, whilst maintaining the optimum level of safety. The concept is destined to benefit from the diverse communication systems that are, or will be offered to the public (GSM, WiFi, BlueTooth, ZigBee ...) and will evolve with concepts of intelligent metering (AMM) as planned in the various countries. The concept addresses all of the basic problems that will have to be faced.:

- Low cost
- Safety
- Billing

Such charging infrastructure can be installed in numerous places

- Home
- Industrial premises
- Office
- Parking lots
- Curbsides.

However, before delving into the system description it is first necessary to understand the basic problems that will have to be solved for the introduction of charging systems and the further development of such systems.

It must be recognized any charging infrastructure must cater for all the urban vehicles that exist, or may exist. There are already many thousands of two wheel electric vehicles that have been sold. They principally charge from normal home domestic plugs or plugs that are available on the street. A large number of electric cars have been sold in Europe that are also capable of being charged from such simple 16 Amp plugs. Many future vehicles will have much the same needs, in particular plug in hybrids that will have only moderately sized batteries. Electric vehicles will also be built with much larger batteries that may need much higher power for charging. Finally, these vehicles will connect to an electric grid that may have different needs to that of the past. The charging infrastructure designer therefore has an almost impossible task: design for the long term

whilst staying compatible with present needs for a cost that must be minimal.

During the early stages of ramp-up, many of the sales will probably be limited to fleets that will be charged in industrial or business parking places. The need for publicly accessible charging spots will however arise rapidly if public sales take off, and the lack of such amenities will certainly limit vehicle acceptance. It is to be noted that only some 20% of French citizens possess a garage. The average European figure is somewhat higher. It will therefore not be sufficient to rely on such domestic or industrial situations. Charging spots will have to be mounted in publicly accessible places (parking lots, curbside ...) some of which will be unattended and subject to vandalism. Spots will have to be safe and vandal proof. Further more, legislation on energy tax used for electric vehicles may also evolve. It is therefore necessary to prepare technology that will robust, safe, reliable, vandal proof and be able to evolve to allow for billing and identification.

2 Minimum global cost

Vehicles do an average of 30 to 60 km per day. This would correspond to 5 to 10 kWh average charge per day. It can thus be expected that each standard charging spot will only dispense one or two Euros of energy per client and would be used one or two times per day. It is therefore clear that the terminal must be as cheap as possible, with minimal maintenance cost and minimal billing costs. Special design steps have to be taken to reduce each one of these cost items.

- Initial cost: the posts use a minimum of components, be manufactured in large numbers with standard low-cost components. Final design will be orientated to mass production.
- Vandalism: the posts must be rugged, simple, with no degradable elements such as displays. The post must remain safe, even if the power plug is destroyed.
- Maintenance: use standard components, and do maintenance work in the factory to cut costs and limit maintenance expenses. It would be preferable to design the mounting posts so that the active elements could be replaced as technology evolves. Visualization and man/machine interfaces are a major cost and reliability problem for maintenance. We have therefore voluntarily removed such items from the simple public

charging spot wherever possible. It is proposed to use the portable telephone or the vehicle interface for all client information and input.

- Billing: This is a major cost item, as each transaction will only concern a few Euros. Many different billing schemes have been studied and we expose the pre-payment system in the latter part of this article as it presents a significant cost reduction. Indeed, it seems best to avoid the need for individual communications for each transaction as such transactions will have a non negligible cost in terms of communication and back office. Such other methods are possible and are not excluded from our approach.

3 Charging safety

3.1 Basic mode 1 and mode 3 protection

The present vehicle-charging infrastructure standard IEC 61851-1 allows for charging from domestic outlets or industrial provided the installation is fitted with a 30 mA differential circuit breaker. This mode of charging has been adopted for all charging situations (domestic, industrial or public) in the vast majority of countries. Most public charging stations are fitted with standard 3 pin industrial (or local domestic) plugs.

The IEC standard also defines higher security options that check for the continuity of the earth line. This method is imposed in the USA and requires a fourth wire as defined in the SAE standard J1772. The present option in the USA is to use a cable that is permanently wired to the wall thus avoiding the need to define a wall mounted socket that has a fourth pin. This solution does not seem to be acceptable for most of Europe unless the charging spot is under surveillance or in protected private property. The car owner will normally supply the cord set under all circumstances, both at home and on the curbside

Sockets with pilot wire pins are proposed however it is considered that basic charging for two wheelers and low cost vehicles should be compatible with readily available plugs and sockets. Using such four-pin sockets could seriously impede the introduction of electric

vehicles, as it would require specific installations that would also be more expensive.

The standard IEC 309-2 single-phase industrial plug seems ideal for this application as it is already used for all outside uses such as caravan supply, and industrial equipment supply. Plugs are available at the hardware stores for a few Euros. Domestic sockets may also be used but it has been found that they may lack reliability for continuous 16A use.

3.2 Earth wire verification using PLC signals

Provision has been made in the new revision of the IEC 61851-1 standard (presently at the CDV voting stage) to allow the use of an electronic signal on the earth line to verify the continuity of the conductor. This allows the use of standard 3 pin plugs. The presence of such a signal is monitored continuously and the AC mains are opened if such a signal is not present. This thus supplies an identical protection to that of a fourth pilot wire. Several options can be proposed using this system:

- Basic protection system without complete data signaling. This kind of system can be implemented using minimal electronic components and would be perfectly suited to electric two wheelers and low cost electric vehicles. Such a system could use a pulsed oscillator system working at the 110 kHz CENELEC frequency. The total implementation cost for the vehicle would be far lower than the use of four pin plugs and a pilot wire as defined for the USA.
- More complete protection system with data exchange. Such a system would allow for extra control functions including load control and billing. This could become the standard system in the long run.

The circuit diagram of the PLC safety system is given in figure 1. This has been presented in the new 61851-1 standard presently at the CDV stage.

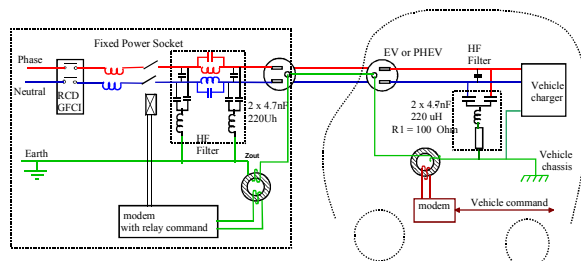

Figure 1: basic circuit diagram of the PLC protection scheme as in proposed CDV.

Filtering in the receiving socket is destined to reduce all emissions to the power line below the out-of-band limit in Clause 7 of EN 50065-1. This is equal to a quasi peak value of 68 dB (μV) at the 110 kHz carrier frequency.

The band pass filters are designed to give minimum impedance at the carrier frequencies. The schema gives typical values that may be used for a 110 kHz carrier.

The resistor R1 in the vehicle circuit is included to limit the carrier current in the earth loop. Good results are obtained for load resistors of 100 Ohms. The transmitter is designed to have internal impedance during sending that is far below this level and an output of 1 V RMS as measured at the output of the ferrite core (Z_{out} on diagram). This circuit has been proven to have a very high rejection rate and is totally insensitive to charger interference. Indeed, the system has been designed to exceed immunity specifications as defined by CISPR 24 by a factor of 10 thus avoiding dysfunction under extreme interference conditions.

It is to be noted that the system has been shown to be fail-safe as any loss of communication stops the charging.

3.3 Supplementary safety functions using data exchange

The data exchange allows supplementary functions that have also been defined for the pilot wire in J1772:

- Identification of the current limit available at the plug outlet, thus increasing the security of the system even further as the vehicle will then only draw the current available at the plug socket.
- Identification of the vehicle and plug voltage can also be done before closing the circuit thus avoiding all over voltage problems.
- Active monitoring of the energy drawn thus reducing risk of over-charge
- Time limited charging to avoid maintaining the power cord active when no current is used.

4 Payment using the PLC system

The PLC signals that ensure the safety features can also exchange identifiers and

payment information at no extra cost. The public charging terminal has an internal energy meter that communicates with the car. The energy credit is contained on the card in the car and is up-dated by the charging terminal. Several methods of payment are proposed.

- Payment using a pre-coded printed card. The client enters the code into the vehicle or telephone interface
- Payment using telephone facilities (common in Japan).

The complete system is designed to operate without a screen on the charging post. Payment information is displayed in the vehicle or on the client telephone. This is of particular interest as it avoids needless cost and limits vandalism.

5 Complete system with telephone communications and ZIGBE

The diagram shows just one example of a full system with all communications for billing and load control in addition to the mode 3 operation using PLC signals.

It is possible to use the CAN interface to display on the vehicle. It is also possible to work without a CAN interface using a portable telephone. We here give a typical example of the use of telephone billing with a pre-payment card.

- The vehicle card will contain an energy credit
- If the energy credit runs low, the client will be informed on his telephone.
- To increase the energy credit the client simply confirms the transaction. All codes are contained on the vehicle card and the telephone giving full security.
- The transaction terminated by the energy company who bills the client on his domestic energy bill.
- Contact of the post with the energy supplier is not necessary in this scheme. It would be possible to have daily or weekly controls as it is done with some credit card systems for small transactions.

It must be remembered that this is only one way of setting up a payment system. This procedure could also be replaced by direct contact of the telephone to the energy supplier with further information transfer to the charging post. This requires several data paths and would normally be much more expensive than that proposed.

It is equally possible to have a parallel payment system with an RFDI badge. This would also require information transfer between the post and the energy supplier.

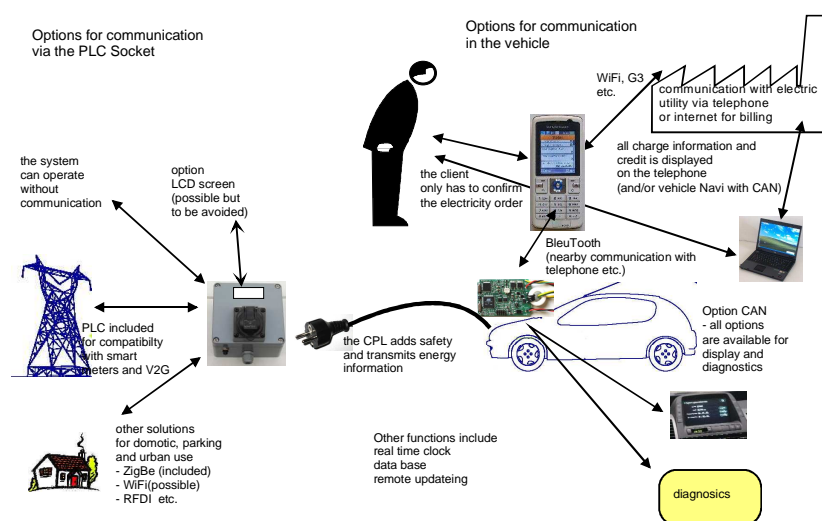

Figure 2 complete communicating charging system

6 Choice of modems

The type of modem defines the data rate. The use of standard CENELEC FSK 110 kHz modems allows the data function and the safety function to be present in the same device. Data rates of 4.8 kBd are possible with this device, but we have chosen to limit the rate in order to correctly ensure safety functions. Data is sent at the beginning of the transaction and very complete information can be sent in some 200 ms.

It is also possible to combine the basic safety system using a 110 kHz carrier with high frequency PLC systems (Home Plug for example). This option does not seem necessary, as there is no need for high data rates for the functions that are desired and this choice would increase the cost unnecessarily. We would not recommend this approach, but it remains a possibility and may be desired by some.

7 Protocol of simple PLC protection and data transfer systems

As indicated earlier, there is a need for both very simple PLC protection systems for scooters and small EVs, and a more complete system having full data capability. These two systems must be compatible, and must function from the same charging spot provided the supply current protection of the charging spot is compatible with the vehicle. The charging spot must therefore detect both systems and react accordingly. The following protocol is proposed as one possible solution.

7.1 Charging spot initiating protocol

The charging spot sends regular signals to the plug, even when the car is not connected. A car, when not connected to a spot will always be in a listening state and will not send signals unless it has received a correctly formatted signal.

The signal sent by the charging spot contains the necessary identification information. The information string will generally be preceded by a blank carrier of some 100ms in duration which is used to wake the vehicle receiving electronics.

7.2 Simple PLC protection protocol without data transfer

The diagram no 3 shows a proposition for protocol that could be used by an “intelligent” charging spot connected to a VE that has no data transfer capacity.

- In the simplest system the vehicle will receive the PLC signal from the Spot but not be able to interpret it. It will simply measure the time from the falling edge of the data stream till the falling edge of the next CPL pulse.
- If the spot does not receive return data from the vehicle it will send a short burst to the vehicle that has its falling edge 1 ms after the falling edge of the previous data signal. It will repeat this twice if there is no response from the first burst. This burst of PLC signal may not have a data content. It will have a length of 150 us to 250 us.
- If the vehicle receives a signal with the right length (150 us to 250 us), with a falling edge exactly 1 ms (+/- 50 us) after the last falling edge of information from the spot it will reply with a burst of between 450 us and 550 us in length.

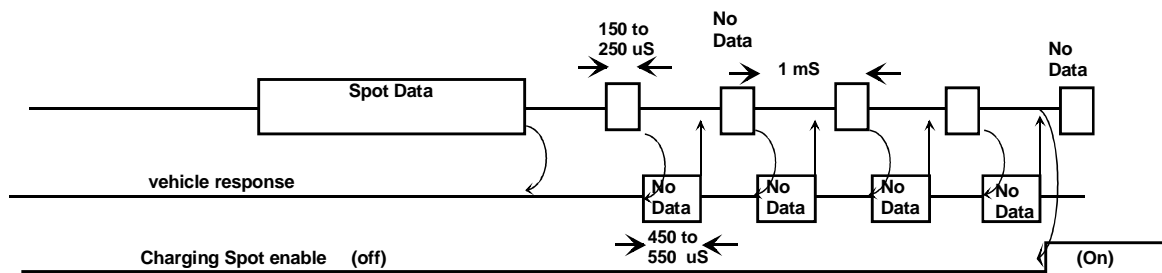

Figure 3: protocol for vehicles without data transfer

- This exchange will be done correctly 4 times before the closing of the charging spot relay.
- Once closed, if there is an absence of 3 exchanges in a total of 20ms, the relay will open.

This protocol can be realized with very simple analog and digital circuits without the need for complex systems on the vehicle.

The protocol is still undergoing test and may be presented as a possible future standard format for vehicle charging.

7.3 Protocol with complete data transfer

- The basic diagram for this kind of interchange is indicated in figure 3b. As in the previous example, the charging spot sends data at regular intervals.

- If the vehicle receives the correct data stream, it will reply with a first set of data.
- The spot replies and will receive a second set of data.
- If the data is coherent, and if all safety and payment conditions are met, the spot will close the supply relay.
- Continuous data streams are sent between the spot and the vehicle. The supply relay will be opened if this data stream is not coherent.

It can be seen that the two vehicle systems can operate using the same charging spot protocol.

For charging spots using simple protocol it will also be possible work with vehicles having the complete protocol.

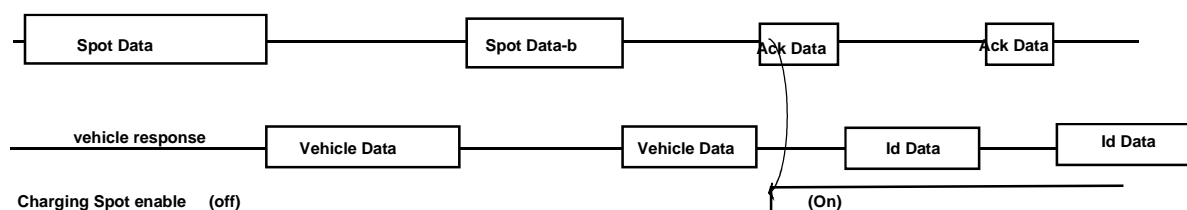

Figure 4: protocol for vehicles with data transfer

7.4 Standardization of charging protocol

The different charging protocols will have to be discussed in detail in the appropriate standardization meeting so that a unified system can be adopted for all of Europe, and eventually for the entire world.

8 Installation on a vehicle

It is expected that installation of this type of system be done by the car manufacturers using only a few extra components that can be added into the existing information system of the vehicle. The extra total component cost would be minimal (a few Euros). Figure 5 shows the minimal component count.

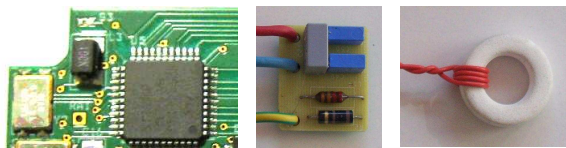

Modem HF filter Ferrite core

Figure 5: minimal additional components necessary for integration into an existing vehicle CPU.

A “starter kit” has also been created that can be integrated directly into existing electric vehicles. It may also be used as a basis of new designs if so wished. This board uses a PLC chip designed on the CENELEC specifications at 110 kHz and allows 4.8 kBd transmission. The present circuit is fully “automobile compatible” being capable of operating over the full -40°C to $+85^{\circ}\text{C}$ temperature range with standard over-voltage protection at all the inputs ($\pm 200\text{V}$ impulse for 12V inputs). We expect that this “starter kit” be used essentially for the retrofit of existing EVs and for vehicles that will be produced in small quantities.



Figure 6: Vehicle PLC circuit.

- Telephone blue tooth compatible
- CAN interface
- PLC interface ...

The block diagram of the vehicle “starter-kit” is shown in figure 7.

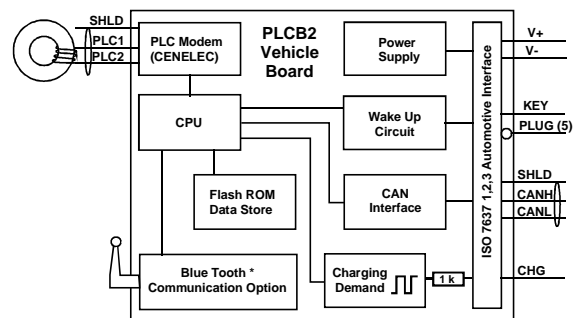

Figure 7 : block diagram of “starter kit”

The “starter kit” tested includes the blue tooth communication. It has been designed to interface with existing vehicles that have the J1772 pilot wire already installed. It is thus possible to up-date existing vehicles to a PLC information system with PLC earth line protection without changing the vehicle.

It is not expected that the starter kit be used “as is” in large-scale production vehicles as it will be far cheaper to integrate the three basic components straight into the original design.

9 Installation into charging infrastructure

This system can be installed into existing charging posts provided there is enough space available for the commutating equipment. The photo below shows the electronic card that fulfills all of the required functions:

- Mains communication
- PLC protection and data transmission to the vehicle
- Metering and billing
- Drive for relay
- Possible extensions for ZigBee and similar systems



Figure 8: charging spot electronic board (74mm x 135 mm)

This equipment may be installed away (up to 20 meters) from the actual power plug thus reducing the visible equipment to a minimum and allowing installation into very small spaces. In this case the system also protects the AC mains wires leading to the remote plugs. These wires will not carry voltage unless a vehicle is connected to the remote plug thus ensuring complete safety.

Three examples of domestic, parking and curbside installations are given in the following pictures.



Figure 9 Simple charging plug in PVC box destined to be used in private locations that are not subject to physical aggression.

The PVC box contains all the necessary protection and electricity meters



Figure 9: Simple charging plug in metal box destined to be used in parking areas that are accessible to the public

The metal box contains all the necessary protection and electricity meters.

It will resist physical aggression

It is a simple box that will not attract undue attention.



Figure 10 : This is one of the many possible examples of charging stations that may be used in high visibility public locations.

The internal electrical systems are identical to the previous examples

Installation costs will include extra costs due to the use in public areas

It is to be noted that the three examples do not use a screen as user interface. Such interfaces can be used and would be used only in non-critical urban areas.

10 Inside view of the Charging Socket

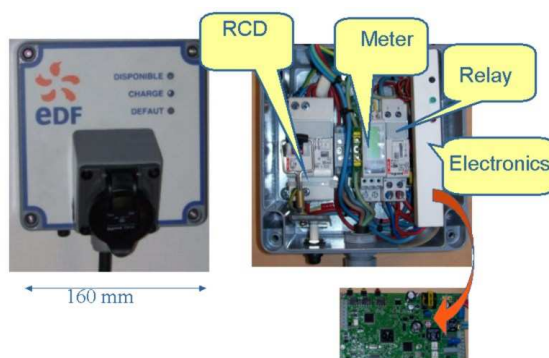

Figure 11: inside view of the minimal charging spot with full information transfer capacity

The picture shows the inside configuration of a prototype socket containing the essential parts

That is necessary for a charging socket

11 Tests done on the system

The fixed plug has undergone full testing for compliance with European standards.

All EMI is inferior to requirements.

The vehicle PLC circuit has undergone extensive susceptibility tests. Specific car manufacturer requirements have been tested on the vehicle “starter kit”.

12 Conclusions

We have described what we consider to be the simplest and cheapest possible charging infrastructure that ensures a very high level of safety and will allow upgrading to all future needs. EDF is willing to share its experience with all stake holders so that we will all be able to construct the best, optimized infrastructure for the future needs of electric mobility. Indeed we must have a sensible approach to this problem, preparing just what is necessary but without compromising future development. The standardization of a simple, unified method is necessary so that the best and cheapest system be available all over Europe, and preferably, all over the world. The technique described in this article has been under-going test over the last 2 years, with success. It is proposed as one possible technique that must be discussed at an international level.

References

- [1] Please refer to the new IEC 61851-1, SAE 1772 standards that are presently being developed.

Author



Cyriacus Bleijs
President of the IEC TC69
standardization committee.
Technical and scientific
Advisor for Electric
Transportation at EDF